

THIS COPY IS PROVIDED ON A RESTRICTED BASIS AND IS NOT TO BE USED IN ANY WAY DETRIMENTAL TO THE INTERESTS OF PANDUIT CORP.

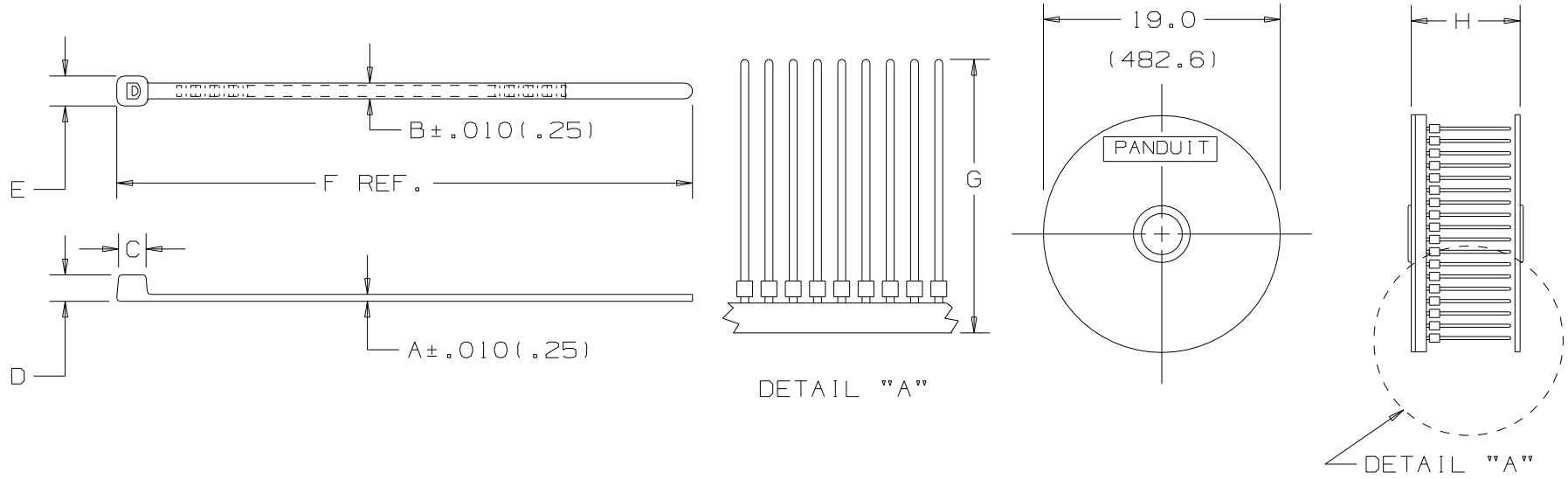

PANDUIT PART NO.	BUNDLE DIA.		A IN. (mm)	B IN. (mm)	C IN. (mm)	D IN. (mm)	E IN. (mm)	F IN. (mm)	G IN. (mm)	H IN. (mm)	MINIMUM LOOP TENSILE lbs. (N)	CROSS SECTION	WEIGHT lbs. (g) /100 pcs
	MIN IN. (mm)	MAX IN. (mm)											
PLT2S-VMR	.06 (1.5)	2.00 (51)	.047 (1.2)	.190 (4.8)	.258 (6.6)	.220 (5.6)	.316 (8.0)	8.1 (206)	8.5 (216)	9.3 (236)	50 (222)	STANDARD	.32 (147)

NOTES:

- *1) SEE CURRENT PRICE SHEET FOR PART COLOR SUFFIX DESIGNATIONS.
- 2) STANDARD PACKAGING: 2500 STRAPS PER REEL, 2 REELS PER CARTON.
- 3) PACKAGED FOR USE WITH PAT2S TOOL AND DISPENSER.
- 4) RECOGNIZED UNDER THE COMPONENT PROGRAM OF UNDERWRITERS LABORATORIES INC.

SS_26588.PRT

CAD FILENAME/LAYERS
DIMENSIONS IN PARENTHESES ARE IN METRIC UNITS

PANDUIT CORP. TINLEY PARK, ILLINOIS
VMR PAN-TY CABLE TIES
PACKAGED FOR AUTOMATIC TOOLS

UNLESS OTHERWISE SPECIFIED,
DIMENSIONAL TOLERANCES ARE:
(.X) ±.10(2.5) (.XXX) ±.020(1.51)
(.XX) ±.02(1.5) ANGLES ±

UNLESS OTHERWISE SPECIFIED,
ALL DIMENSIONS ARE GIVEN
IN INCHES, THIRD ANGLE PROJECTION.

DRAWN BY
RAM
DATE
4/8/92
CHK'D
HVP

MAT'L:
NYLON 6.6

SCALE
NONE
DRAWING NO.
SS-26588
DWG
A
SIZE

1	4/25/07	JABO		DRAWING RELEASED	25688	1							
REV	DATE	BY	CHK	DESCRIPTION	ECN	R	CUST	SUP					